



MRC-11X

Motorcycle Radio Communicator



OWNER'S MANUAL





CONTENTS

Introduction and General Description	3
Advanced Features Summary	4
Standard Features Summary	4
Warnings	4
To Be Safe	5
Care and Maintenance	6
Exposure to Radio Frequency Energy	6
Included and Optional Accessories	7
Installing Batteries	7
Recharging Ni-CAD or Ni-MH Batteries	8
A Quick Look at Your Radio	9
Controls	10
LCD Display Description	11
Low Batteries Power Indication	12
Using the Belt Clip	12
Using External Microphone/Speaker Headsets	12
Operation Manual	13
Turning On with the PWR/SET Key	13
Setting Volume level with the UP and DOWN Keys	13
Receiving an Incoming Call (Standby Mode)	13
Transmitting a Signal Using the PTT Key	13
Calling Another Party with the CALL Key	13
Dual Channels Receiver and Transmit (Dual Watch Mode)	13
Radio & Intercom/Intercom	14
VOX (voice-activated hands-free operation)	14
Key Lock	14
Scan (Auto Monitor)	14
CTCSS code set	15
Auto Squelch	15
Stopwatch	15
AUD (Stereo Auxiliary Audio Input) Jack	15
Driver / Passenger + charger jacks with external PTT	15
Setting Functions	16
Setting Calling Tone Type	17
Optimizing Range	17
General Specifications	18
Troubleshooting	19
CTCSS Codes	20
FRS / GMRS 22 Channel Chart	20
Channel Cross Reference Chart	21
Licensing Information	22
Service	22
Navigating Menu	23
Call Tone Setting	23



INTRODUCTION AND GENERAL DESCRIPTION

Introduction:

Congratulations for your purchase of the MRC-11X bike-to-bike radio communicator with driver/passenger intercom. Designed with special features for motorcycle, snowmobile and other helmet/hard hat applications, the Nady MRC-11X offers the most advanced portable communication technology available to allow you to stay connected on the road. Offering several times the range of previous generation motorcycle communicators, the MRC-11X provides maximum clarity and effortless communication in the real world of motorcycle riding environments. Because the MRC-11X operates with higher power on the special new uncluttered UHF FRS/GMRS (U.S.) frequencies, you can now speak with another cyclist up to 7 miles away (depending on the terrain) without interference.

Welcome to the next generation of personal communication: FRS & GMRS.

The FCC (Federal Communication Commission) has created 14 license free frequency bands, or channels, called Family Radio Service (FRS) frequencies, and 15 licensed channels for General Mobile Radio Service (GMRS). These channels are in the UHF (Ultra High Frequency) band, which virtually assures crystal clear reception even in crowded noisy environments. This two-way, short-range voice radio service lets families and groups keep in touch with each other on specific service channels. The MRC-11X is compatible with other brands utilizing the same frequency band (operating in the frequency range from 462.563MHz to 467.713MHz).

General Description:

Your MRC-11X includes a basic FRS and GMRS radio with 38 CTCSS tones and 22 channels (FRS & GMRS-7 channels FRS only, 8 channels GMRS only, & 7 channels shared GMRS/FRS frequencies), and crystal clear communication range of up to 7 miles on the GMRS only channels. It provides excellent communication range and voice quality, and user-friendly features. With special features for use with motorcycles, the MRC-11X is designed to maximize your on-the-road communications. The two-way radio can be voice-operated by either the driver or passenger (VOX) or operated manually by either a remote PTT button mounted on the handlebar or the large push-to-talk button (PTT) on the unit. The radio operates simplex (one-way-at-a-time) mode for use by any number of riders on separate motorcycles. The driver/passenger intercom is full duplex (simultaneous two-way). Auxiliary stereo input allows you and your passenger to listen to CD, tape players, or other external music sources.

To assure the maximum performance of your unit, read these instructions carefully and retain them for future reference.





ADVANCED FEATURES SUMMARY

- FRS, GMRS, & shared FRS/GMRS (22 channels total / 462-467MHz)
- Choice of 6 distinct Call tones for calling each of 6 other parties individually
- 38 CTCSS privacy (lockout) tones
- VOX (hands-free) transmission with 4-level sensitivity adjust user selectable for optimizing accurate triggering with varying background noise
- Driver/Passenger Full duplex intercom (Simultaneous two-way)
- AUX. (Stereo Audio Input)
- Two-level transmit power automatically selected:
FRS channels: Low=0.5W, up to 2 mile range
GMRS channels: High=3.0W, up to 7 mile range
- Software Set key for all controls
- Auto dual channel monitoring (receive and transmit)
- Special noise reduction circuitry for quieter operation
- Stopwatch

STANDARD FEATURES SUMMARY

- Battery power low indication on LCD
- Six-level digital speaker volume select
- Auto squelch
- Auto Scan and Manual Monitor
- Power on beep tone
- Beep tone for confirmation of key
- Key lock on/off selectable
- Back light LCD with 18 function readout
- Dual channel or basic channel selectable
- Max 1.3 Minute per time for transmit (for Protect)
- Page / Calling button
- Monitor / Scan button
- Internal EEPROM for automatically saving data entered
- Auto save of last settings when unit is shut off
- All channels can store different CTCSS code.
- Auto power save (standby mode)

WARNINGS

- While this unit has been designed for ruggedness, it is a precision piece of electronic equipment that should not be exposed to water or handled carelessly. Normal care should result in years of trouble-free operation.
- Do not leave batteries installed over a long period of time as leakage may occur, which can destroy the unit. All batteries can cause property damage and/or bodily injury, such as burns, if conductive material such as jewelry, keys or beaded chains touch exposed terminals. The material may complete an electrical circuit (short circuit) and become quite hot. Exercise care in handling any charged battery, particularly when placing it inside a pocket, purse or other container with metal objects.
- The antenna is permanently attached to the unit. Never attempt to remove it. Do not use any unit that has a damaged antenna. If a damaged antenna comes in contact with the skin, It may cause a minor burn.
- For vehicles with an air bag: Do not place your unit in the area over an air bag or in the airbag deployment area. Air bags inflate with great force. If a unit is placed in the air bag deployment area and the air bag inflates, the unit may be propelled with great force and cause serious injury to the occupants of the vehicle.



WARNINGS

- Potentially Explosive Atmospheres: Turn your unit OFF when in any area with a potentially explosive atmosphere, such as at a gasoline station filling area. Sparks in such areas could cause an explosion or fire, resulting in bodily injury or even death. Do not replace or charge batteries in a potentially explosive atmosphere. Contact sparking may occur while installing or removing batteries and cause an explosion. *NOTE: Areas with potentially explosive atmospheres are often but not always, clearly marked. They include fueling areas such as below deck on boats, fuel or chemical transfer or storage facilities: areas where the air contains chemicals or particles, such as grain, dust, or metal powders: and any other area where you would normally be advised to turn off your vehicle engine.*
- Blasting Areas: To avoid possible interference with blasting operations, turn your unit OFF near electrical blasting caps or in a blasting area or in areas posted. Obey all signs and instructions.
- Never connect this unit to more than 7.5 volts as will seriously damage the unit and void the warranty. Never, for example, attempt to hook up external power to the CHG (charger) power input from the motorcycle's cigarette lighter or other source of 12V. You cannot operate the unit on external power.
- Do not open your radio to make any internal adjustments. Your radio is set up to transmit a regulated signal on one of the 22 assigned frequencies (FRS/GMRS). It is against the law to alter or adjust the setting inside the radio to exceed those limitations. Any adjustment to your radio must be made by a qualified technician using the proper test equipment. Note that such tampering will void the warranty.
- Always save your receipt as you will need it to establish proof-of-purchase date if your unit ever needs service under the warranty.

TO BE SAFE

Never open your radio's case. Modifying or tampering with the radio's internal components can cause a malfunction and invalidate its warranty and void your FCC authorization to operate it. If your radio it not performing as it should, call the NADY Service department (see page 22).

Never change or replace anything in your radio except the batteries
Your radio might cause TV or radio interference even when it is operating properly. To determine whether your radio is causing the interference, turn it off. If the interference goes away, your radio is causing it. Eliminate the interference by moving your radio away from the receiver.

If you cannot eliminate the interference, the FCC requires that you stop using the radio.

This device complies with part 15 of the FCC Rules. Operation is subject to the following two conditions:

- This device may not cause harmful interference.
- This device must accept any interference received, including interference that may cause undesired operation.





EXPOSURE TO RADIO FREQUENCY ENERGY

The design of your MRC-11X, which generates radio frequency (RF) electromagnetic energy (EME), complies with the following national and international standards and guidelines.

- FCC Report and Order FCC 96- 326 (August, 1996)
- American National Standards Institute (C95- 1- 1992)
- National Council on Radiation Protection and Measurements (NCRP - 1986)
- International Commission on Non- Ionizing Radiation Protection (ICNRP - 1986)

To ensure optimal unit performance and to ensure that exposure to RF energy is within the guidelines in the above standards, the following operating procedures should be observed:

For Portable Two-Way Communicators

- When transmitting with a handheld MRC-11X, hold the unit in a vertical position with its microphone 1 to 2 inches (2. 5 to 5.0 cm) away from your mouth. Keep the antenna at least 1 inch (2.5cm) from your head and body.
- If you wear the unit on your body, ensure that the antenna is at least one inch (2.5cm) from your body when transmitting.

Electromagnetic Interference/ Compatibility

Nearly every electronic device is susceptible to electromagnetic interference (EMI) of inadequately shielded, designed or otherwise configured for electromagnetic compatibility.

- Turn your unit OFF in any facilities where posted notices instruct you to do so. Hospitals or health care facilities may be using equipment that is sensitive to external RF energy.
- Turn your unit OFF when on board an aircraft when instructed to do so. Any use of the unit must be in accordance with airline regulations or crew instructions.

CARE AND MAINTENANCE

To enjoy your radio for a long time:

- Keep the radio dry. If the unit gets wet, turn it off and remove the batteries immediately. Dry the battery compartment with a soft cloth to minimize potential water damage. Leave cover off the battery compartment overnight or until completely dry. Do not use the unit until completely dry.
- Use and store the radio only in normal temperature environments.
- Handle the radio gently and carefully. Do not drop it.
- Keep the radio away from dust and dirt.
- Wipe the radio with a damp cloth occasionally to keep it looking new.
- Don't use cleaners or solvents on the unit; they can harm the case and leak inside, causing permanent damage. Battery contacts may be wiped with a dry, lint- free cloth.



INCLUDED AND OPTIONAL ACCESSORIES

The following is included in each package:

- MRC-11X Motorcycle Communicator
- MHS-11XO premium open-face helmet-mount headset with microphone for driver and ext. PTT button
- User Manual
- Warranty Card
- Optional Accessories Ordering Form

The following are optional accessories (see also included Optional Accessories Ordering Form):

- MHS-11XO premium open-face helmet-mount headset with microphone for driver or passenger and ext. PTT button
- MHS-11XC premium closed-face helmet-mount headset with microphone for driver or passenger and ext. PTT button
- MO-1 standard open-face helmet-mount headset with microphone for passenger
- MC-1 standard closed-face helmet-mount headset with microphone for driver or passenger
- BC-11X battery charger (for 100-240V ~ 50/60Hz input) for internally charging the MRC-11X batteries (plugs into the PSG/CHG jack)

INSTALLING BATTERIES

Your radio requires four AAA alkaline or NiCad or NiMH Rechargeable batteries for power. For the best performance and longest life, please note the following cautions:

- Use only fresh batteries of the required size and recommended type.
- Do not mix old and new batteries, different type of batteries (alkaline or rechargeable), or rechargeable batteries of different capacity.
- Follow these steps to install batteries.

- 1) Turn off the radio. Remove belt clip and slide off the battery compartment cover.
- 2) Install four AAA batteries according to the polarity symbols (+ and -) marked inside.
- 3) Replace the cover and belt clip.

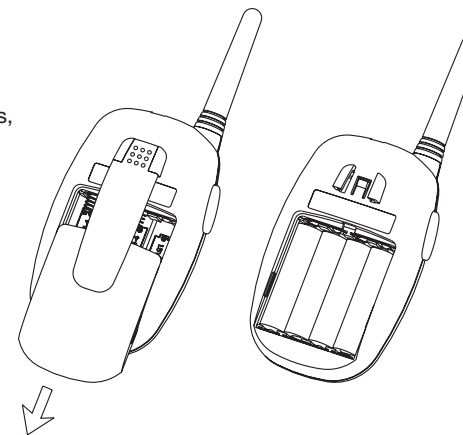

Note:

- 1) Dispose of old batteries promptly and properly. Do not burn them.
- 2) If you do not plan to use the unit for a month or longer, remove the batteries. Batteries can leak chemicals that can destroy electronic parts. The warranty does not cover damage caused by leaking batteries.





RECHARGING NI-CAD OR NI-MH BATTERIES

See *Low Batteries Power Indication* section on page 12, for instructions for determining when batteries are low.

Warning:

- Do not attempt to charge alkaline batteries. Non-rechargeable batteries can get hot or explode if you try to recharge them. **Never attempt to charge non-rechargeable batteries.**
- If you use rechargeable Ni-CAD or Ni-MH batteries, you can recharge them between uses externally in any appropriate commercially available charger or you can recharge them internally (in the unit) using the optional BC-11X adapter (see *Optional Accessories Ordering Form* included).
Please note: (1) Do not attempt to use any other adapter than the optional BC-11X for charging the batteries as they can damage the unit. (2) You cannot power the unit with the optional BC-11X as the unit can only be powered for operation with the internal batteries.
- Internally charging the batteries with the optional BC-11X charger:
 - 1) Use the PWR/SET button to turn off the MRC-11X (the unit can not be charged when it is on)
 - 2) Slide off the battery compartment cover, and install the batteries.
 - 3) Connect the charger's RS (Ring-Sleeve) plug to the radio's PSG/CHG jack and plug its other end to a standard AC outlet.
 - 4) A complete charge takes about 7 hours.

(Note: do not charge for longer periods as overcharging can damage the batteries)



A QUICK LOOK AT YOUR RADIO

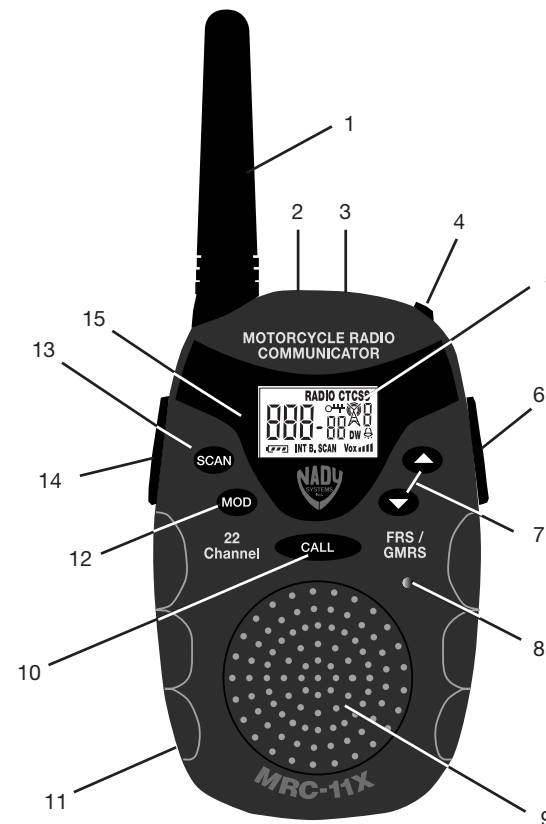

1. Antenna
2. DRV (driver headset) jack
3. PSG/CHG (passenger headset/internal charging) jack
4. PWR/SET (on-off/mode selected set) button (key)
5. LCD display
6. AUX (auxiliary music source input) jack
7. UP/DOWN (select) buttons (keys)
8. Internal microphone
9. Internal speaker
10. CALL button (key)
11. Battery compartment (on back)
12. MOD (mode select) button (key)
13. SCAN (scan/monitor select) button (key)
14. PTT (push-to-talk) button (key)
15. TX (Transmit) LED indicator





CONTROLS

- PWR/SET key
 1. Press and hold key for over 3 seconds to turn the power on/off
 2. Press momentarily to set data selected and to exit to standby after setting mode
- DOWN key
 1. Press key momentarily to set channel when in the channel set mode
 2. Press and hold key for over 2 seconds in standby to turn VOX on/off
 3. Press key momentarily in standby to turn volume level down
- UP key
 1. Press key momentarily to set channel when in the channel set mode
 2. Press and hold key for over 2 seconds in standby to set key lock or key unlock
 3. Press key momentarily in standby to turn volume level up
- PTT key

Press and hold to transmit (talk)
- CALL key
 1. Press momentarily in standby to call other parties with preset call tone in standby
 2. Press and hold for over 2 seconds in standby to switch into stopwatch mode
- SCAN key
 1. Press momentarily in standby to defeat autosquelch for monitoring
 2. Press and hold in standby for 2 seconds to auto scan all channels
- MODE key
 1. Press and hold key in standby for over 2 seconds to enter set mode.
 2. Press key in set mode to select the next mode.
- BACK-LIGHT will turn on if any keys are pressed and turn off 5 seconds after pressing the last key

Note: If you already have experience in operating such radios, after familiarizing yourself with the controls of the MRC-11X you may wish to just go directly to the Navigation Menu on page 23.



LCD DISPLAY DESCRIPTION

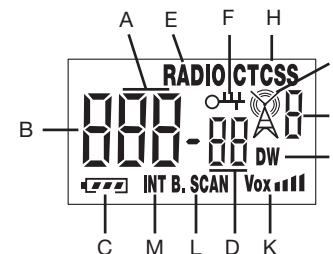

- A) Channel Number. Changes from 1 to 22 as selected by user.
- B) Displays either an L (for FRS low power mode) or an H (for GMRS high power mode).
- C) Battery power level indicator. Displays the current battery level charge.
- D) Displays the current CTCSS code.
- E) RADIO ON indicator
- F) Key Lock ON indicator
- G) Transmit mode, Receive mode indicators
- H) CTCSS ON indicator
- I) Volume level indicator. Changes from 1 to 6 as selected by user.
- J) Dual Watch monitoring mode (dual channel)
- K) Voice level sensitivity indicator for VOX hands-free operation. Displays the current VOX level selected (1-4).
- L) Basic Channel Mode indicator
- M) Displays "INT" when in intercom mode

DISPLAY	DESCRIPTION
	Key lock ON
	Transmit mode Receive mode
	Battery power level indicator
INT	Intercom
B. SCAN	Basic channel mode
Vox	Voice level for VOX hand-free
DW	Dual channel mode
CTCSS	CTCSS on
RADIO	RADIO mode
	Stopwatch mode: for minute of clock - for second of clock, for mil-second
	FRS mode: for channel number - for CTCSS number





LOW BATTERIES POWER INDICATION

As you use the unit, the battery icon's elements will disappear one by one to show the remaining power. When only one element remains, replace alkaline batteries or recharge NiCad or Ni-MH batteries as soon as possible.



USING THE BELT CLIP

To use the supplied belt clip, insert the clip fully into the slot at the back of the radio unit. To remove the clip, press the top of the clip and slide it out. The belt clip needs to be removed before changing/installing the batteries for full access to the battery compartment.

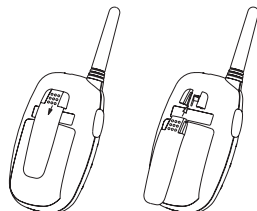

USING EXTERNAL MICROPHONE/SPEAKER HEADSETS

The MRC-11X is supplied with an MHS-11XO headset for the driver. If the unit will also be used for driver/passenger communications, an optional second headset can be purchased for the passenger (see the Optional Accessories Ordering Form enclosed for more info re the choice of the premium MHS-11XC/O or the standard MO-1/MC-1 headsets). When the driver headset is plugged into the DRV jack on the unit's top panel, it automatically disables the MRC-11X's built-in Mic and speaker, and the headset must be used for all communication.

(Note: Always make sure the unit is off or the volume at minimum before plugging in the headsets and placing them on the head.)

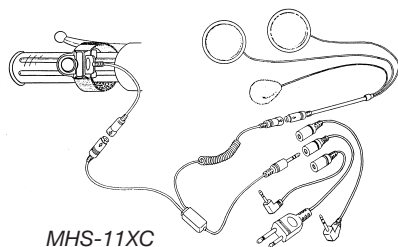

MHS-11XC

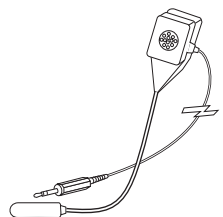

MO-1

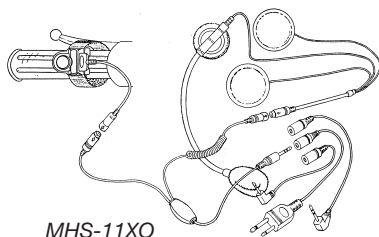

MHS-11XO

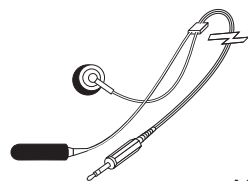

MC-1



OPERATION MANUAL

Turning On with the PWR/SET Key

Press and hold the PWR/SET key for over 3 seconds to turn the unit on/off. The unit will "beep" when turning the unit on/off and the LCD screen will light when unit is on.

Setting Volume level with the UP and DOWN Keys

Press either the UP or DOWN keys once momentarily to enter volume setting mode. Press the UP key or DOWN key again to increase or decrease volume level from 1 to 6 as shown on the volume icon of the LCD display. Press the PWR/SET key momentarily to set or it will automatically set in 15 seconds. A beep will sound to confirm this setting.

Receiving an Incoming Call (Standby Mode)

In standby mode (not programming or selecting functions), the unit automatically will receive incoming calls from any other unit on the same channel and CTCSS code whenever you are not talking/transmitting. When you receive a signal, the (X) icon appears on the display.

Transmitting a Signal Using the PTT Key

Check the channel activity by pressing and holding the SCAN button. You will hear static if the channel is unoccupied. Do not TRANSMIT if someone is talking on the channel. Press and hold the PTT button to TRANSMIT. The (M) icon is displayed. The TX LED indicator will light up in red. Hold the unit in a vertical position with the MICROPHONE 1 to 2 inches from the mouth. While holding the PTT button, speak into the unit using a normal tone of voice. Release the PTT button when you have finished transmitting. The automatic end-of-message "Roger" tone will sound and you can then listen for another party's response.

NOTE: In order for other people to receive your transmission, they must also be on the same channel you are currently using. Refer to the Changing Channels section for more information.

After you hold down the TALK key continuously for about 80 seconds, the unit will automatically stop your transmission to save power. If necessary to continue transmitting, wait a few seconds before proceeding.

Calling Another Party with the CALL Key

Use the CALL key to alert another party you wish to communicate with them. Both units must be set to the same channel and CTCSS code. Momentarily press and release the CALL key to call the other party with a 3-second calling alert tone. Wait for the party's response or proceed to "Talking to Another Party using the PTT Key". See pg. 17 for instructions on how to select one of 6 different call tones for individual paging when using your unit with a group. You can also use the CALL Tones to signal the beginning or the end of a transmission.

Dual Channels Receiver and Transmit (Dual Watch Mode)

Dual channels reception: If the dual channels setting is OFF, the (B. SCAN) icon appears on the display and you only have the basic single channel reception. If the





OPERATION MANUAL

dual channels setting is selected ON, the (**DW**) icon appears on the display and the unit will receive one either of the dual channel selected (basic channel and second channel). This Dual Watch monitor mode is especially useful when the signal you want to hear is consistently weak

Dual channels transmission: If the dual channels in on, the (**DW**) icon appears on the display and the unit can transmit on either of dual channels (basic channel and second channel). Hold down the TALK key to the transmit on the basic channel, and press and release the MODE key and then hold down the TALK key to transmit on the second channel (the second channel number will then appear on the display).

Radio & Intercom / Intercom

Intercom only: In the Intercom mode (**INT**) icon, insert the driver and passenger headsets into the appropriate jacks on the top panel as marked on the rubber cover plug. The driver and the passenger can then communicate with each other simultaneously (full duplex).

Radio & intercom: In the Radio & Intercom mode (**RADIO**) icon, when the driver and the passenger headsets are connected, the unit will automatically also be in the Intercom mode. Both headsets will hear any received audio and both of the microphones are able to transmit audio and trigger the VOX.

VOX (voice-activated hands-free operation)

In standby mode, press and hold the DOWN key for over 2 seconds to turn the VOX on/off. The VOX (**Vox**) icon appears on the display whenever the VOX mode is turned on. To optimize the VOX operation, you can select 1 of 4 different input volume levels for triggering the VOX, depending on the background ambient noise and your speaking level. See “Setting Functions”, pg. 16, for instructions for choosing the VOX level desired.

Key Lock

The purpose of the Lock function is to lock most keys to avoid accidental operation. In standby mode, press and hold the UP key for over 2 seconds to turn on the key lock. The (**☞**) icon appears on the display. Press and hold the UP key again to turn off the key lock. While the unit is set to the key lock status, only the TALK, UP and SCAN keys will have any response.

Scan (Auto Monitor)

Auto Monitor: When the signal you want to hear is consistently weak, you may place the radio in monitor mode, which will defeat the auto squelch, and thus prevent the muting of weak signals. However, between receptions you will then also hear the normal loud radio hiss, since the auto squelch is off. Press the SCAN key momentarily to enter monitor mode. To return to normal operation, press any key. See also “Auto Squelch”.

Scan: Press and hold SCAN key for over 2 seconds to start scanning all the channels in the up direction. To exit the scan mode and select the channel being displayed at any point to be the basic channel, press any other key.



OPERATION MANUAL

CTCSS code set

You can select any one of the 38 available CTCSS privacy (lockout) codes for each of the 22 channels while the CTCSS icon is flashing. See pg. 16, “Setting Functions” for instructions for how to enter CTCSS Select mode to get CTCSS icon to flash. Press the UP or DOWN key to select the desired code number for that channel. Press the MOD key again to save the CTCSS number selected. Press the PWR/SET key momentarily to exit.

Auto Squelch

This unit is equipped with an auto squelch that we'll automatically shut off weak transmissions and unwanted noise due to terrain conditions or if you reach the operating range limit. It can be defeated (turned off) by pressing the SCAN key. See also “Scan (Auto Monitoring) pg 14.

Stopwatch

To enter the stopwatch mode, press and hold the CALL key for over 2 seconds. In stopwatch mode, press the TALK key to start count, and press the TALK key again to stop. While the watch is stopped, press the CALL key to reset the counter, press the TALK key to restart the watch. To freeze the LCD display while counting, press the CALL key once momentarily. To pick up the current count, press the CALL key once again momentarily. Press any of the other keys to exit stopwatch mode at any time and set the unit into standby mode.

AUX (Stereo Auxiliary Audio Input) Jack

A tape player, radio or CD (or any other external music source) can be connected to the AUX (Auxiliary In) stereo jack to allow both the driver and passenger (if any) to also hear music while either conversing with each other or with other bikes. This function works in any mode, and the AUX audio will not be transmitted or heard by the other parties you are communicating with. The audio level heard needs to be adjusted with the volume adjust knob of the music source.

Driver / Passenger + charger jacks with external PTT

The MRC-11X is specially designed with DRV/PSG+CHG jacks with external PTT (push-to-talk) capability. Both the DRV and PSG jacks accept the MHS-11X (C or O) headset/microphone for motorcycle, with external PTT mounting on the handlebar (one headset is supplied with the unit). If the unit will also be used for driver/passenger communications, an optional MO-1 or MC-1 headset for the PSG jack is needed (see the enclosed Optional Ordering Form for Accessories). When the driver headset is plugged into the DRV jack on the unit's top panel, it automatically disables the MRC-11X's built-in Mic and speaker, and the headset must be used for all communication. The PSG jack also accepts the external optional BC-11X battery charger to charge the Ni-CAD or Ni-MH rechargeable batteries internally. For charging instruction see pg. 8, “Recharging Ni-CAD or Ni-MH Batteries”.





OPERATION MANUAL

Setting Functions

For all the function set modes:

- Press the MODE key to save the set number selected and enter the next set mode. Press the PWR/SET key to save the set number and exit the set mode. Press the UP key or DOWN key to change the set number or status. Press any other keys to exit the set mode.
- While the unit is in standby mode, press the MOD key for 2 seconds (till unit beeps) to enter the set mode. This allows a choice of seven different sequential modes to set: (1) Basic channel select, (2) Basic CTCSS code number selected, (3) VOX level select, (4) Dual channel scan, (5) Second channel select, (6) Second CTCSS code number select, (7) Radio/Intercom or Intercom select. Press PWR/SET key anytime to set selection and return to standby mode.

- **(1) Basic channel select:** While the unit in set mode, press the UP key to increase the channel, press the DOWN key to decrease the channel. Press the MODE key momentarily (unit will beep) to save the selected basic channel and to set the CTCSS code for the basic channel selected.
- **(2) Basic CTCSS code number selected:** Press the DOWN key or the UP key to change the CTCSS code. Press the MODE key again to save the CTCSS number selected and to set the VOX level.
- **(3) VOX level select:** Press the UP key or the DOWN key to select one of the 4 different VOX sensitivity levels. Press the MODE key to save the VOX level selected and to set the dual channel mode on or off.
- **(4) Dual channel scan:** Press either the UP or the DOWN key to turn the dual channel scan on or off. Press the MODE key to save channel status and enter next mode. When the dual channel mode is set to on, and the **(DW)** icon is displayed, you can set the second channel. When the dual channel scan is set to off, proceed to (7) Radio/Intercom mode.
- **(5) Second channel select:** Press the UP or DOWN key to select the channel and the MODE key again to save the second channel and to set the second channel CTCSS code.
- **(6) Second CTCSS code number select:** Press the UP or DOWN key to select the CTCSS code and the MODE key again to save second channel CTCSS code and to set the Radio/Intercom on/off.
- **(7) Radio/Intercom or Intercom select:** Press either the UP or DOWN key to select between Radio/Intercom (both **RADIO** and **INT** icons displayed) or intercom (**INT** icon) only. Press either the MODE or PWR/SET key again to save all status and exit set mode back to standby.



OPERATION MANUAL

Setting Calling Tone Type

When the unit is off, press and hold the PWR/SET key and the SCAN key simultaneously till the unit beeps. The unit's full LCD display, showing all icons, will light up. You can now select the call tone type.

Press the CALL key to sound the first choice of 6 different call tones available. You can either press the CALL button again in sequence to select and sound the other available tones or scroll through them all with the UP and DOWN buttons. When you have the call you wish to transmit selected, press either the MOD or the SET key to save. This tone will now be transmitted whenever you press the CALL button in standby mode until you select another tone. Press SET key again to turn the power off.

See also the section **Call Tone Setting** in the **Navigating Menu**, page 23

Optimizing Range

Your MRC-11X radio has a range of up to 2 miles for 0.5 watts, up to 7 miles for 3.0 watts under the most ideal conditions such as wide, open flat terrain. This effective range can be shortened by signal attenuation caused by buildings, vehicles, and other obstructions such as dense foliage and hilly terrain.

- UHF operation allows the MRC-11X to provide communication that is virtually free of the atmospheric interference that is often common with lower frequency bands. Additionally, higher power and an antenna system that is very efficient as compared to other unlicensed radio bands (such as 49MHz) often used for motorcycle communicators, further enable the farther operating range of the MRC-11X.
- Often the limits to maximum possible range are environment factors such as blockage caused by trees, buildings, hills or other obstructions. Sometimes you may find communication suddenly not possible (localized dropout zone), and this can almost always be overcome by moving only a few feet to a new location. Be aware that the range may be greatly reduced while operating in a vehicle or metal building.
- Battery condition also effects range, with fresher batteries providing greater transmitted output power. The MRC-11X operates on rechargeable Ni-CAD or Ni-MH batteries or ordinary alkaline batteries.
- Since the body absorbs some radiated energy, thus reducing range, note that holding the unit in your hand, or mounting it on your bike's handlebars (so the unit is away from your body) will ultimately maximize range under all conditions. However, normal mounting on your belt or clothing is often more convenient and should provide sufficient range for most bike-to-bike communications. If maximum range is needed, experiment with the unit placement for best performance.

Note: This unit cannot ensure privacy in communications.





GENERAL SPECIFICATIONS

Operating Frequency Range	462.563MHz-467.713MHz
Number of Channels	22 total/GMRS + FRS
Effective Radiated Power	GMRS channels: 3W @ 6.0VDC FRS channels: 500mW @ 6.0VDC (power automatically selected for channels as required by FCC)
Range	Up to 7 miles (11Km) line-of-sight, 3/4 to 2 miles typical
Modulation	FM, +/-1.5kHz
Carrier Frequency stability	+/- 2PPM
Harmonic Suppression	>50dB
Carrier Attack Time	30ms
Receiver I.F. Frequencies	1st: 21.6MHz, 2nd: 455KHz
Receiver Sensitivity (12 dB Sinad)	0.4uV
Receiver Selectivity	50dB
Max S/N ratio @-60dBm RF input	50dB
Squelch sensitivity	-118dBm
Attack time	120ms
Closing time	200ms
Nominal Audio Output	200mW
Audio Frequency Response	300-3000Hz
Audio distortion	<1% (@1KHz deviation and 1mV RF input)
Max. Audio Output @10% THD	350mW
Internal Speaker (deactivated when using headset)	8 ohm/0.25W
Internal Microphone (deactivated when using headset)	Electret condenser
Microphone Sensitivity	10mV @ 1.5KHz deviation
Low Battery Display Threshold	4.3-4.6VDC
Transmit Current (4.6VDC High Power)	<0.8A (TX); <30mA (STBY); <100mA (RX)
Current Drain (Intercom)	<100mA
Standby Current (4.6VDC)	<30mA
Power Required	4 Ni-Cad, NiMH or Alkaline AAA batteries (4.6-6.0 VDC)
Battery Life 4.6VDC (4xAAA)	>48 HR (RX)
Max. Audio output @ 10% THD Current	<200mA
Dimensions/Weight	2.5" X 4.0" X 1.0" (63.4 X 101.6 X 25.4mm) 5.1oz / 143g (without batteries)



TROUBLESHOOTING

SYMPTOM — No Power

SOLUTION

- Check batteries. Ensure that the batteries are installed correctly
- The batteries may be weak.
- Replace old batteries with four (4) new AAA alkaline or fully charged Ni- MH or NiCad rechargeable batteries.

SYMPTOM — Weak Reception

SOLUTION

- Press the UP button to increase VOLUME.
- The receiving signal may be weak and/ or out of range. If this happens press the SCAN button to defeat the AutoSquelch .

SYMPTOM — Can Not Change Channels

SOLUTION

- To change channels, press the MOD button until the Channel number flashes on the LCD Screen. Press the UP or DOWN button to change channels.
- Batteries may be weak and need replacement. Replace with new batteries if the BATTERY CHARGE LEVEL indicator is low.

SYMPTOM — Limited Range

SOLUTION

- Batteries may be weak and need replacement. Replace with new batteries if the BATTERY CHARGE LEVEL indicator is low.
- The maximum range will vary depending on terrain and environment. Open fields provide the maximum range, while structures, heavy foliage and use in buildings and in vehicles may limit the range significantly.
- Wearing the radio close to the body, such as in a pocket or on a belt, will decrease range. Change the location of the radio away from the body for optimum range under any conditions.

SYMPTOM — Sound Distortion Problems

SOLUTION

- If you are transmitting, speak in a normal tone of voice, 1 to 2 inches away from the MICROPHONE.
- If you are receiving, lower the VOLUME to a comfortable level.
- Radios may be too close. Radios must be at least 5 feet apart. Increase your separation distance.
- Radios too far apart. Obstacles may be interfering with transmission. Shorten your operating distance.





CTCSS CODES

CODE NO.	ASSIGNMENT FREQ (HZ)	CODE NO.	ASSIGNMENT FREQ (HZ)	CODE NO.	ASSIGNMENT FREQ (HZ)
0	No Code	13	103.5	26	162.2
1	67.0	14	107.2	27	167.9
2	71.9	15	110.9	28	173.8
3	74.4	16	114.8	29	179.9
4	77.0	17	118.8	30	186.2
5	79.7	18	123.0	31	192.8
6	82.5	19	127.0	32	203.5
7	85.4	20	131.8	33	210.7
8	88.5	21	136.5	34	218.1
9	91.5	22	141.3	35	225.7
10	94.8	23	146.2	36	233.6
11	97.4	24	151.4	37	241.8
12	100.0	25	156.7	38	250.3

FRS / GMRS 22 CHANNEL CHART

NO.	FREQ (HZ)	NO.	FREQ (HZ)	NO.	FREQ (HZ)
1	462.563	9	467.588	17	462.600
2	462.588	10	467.613	18	462.625
3	462.613	11	467.638	19	462.650
4	462.638	12	467.663	20	462.675
5	462.663	13	467.688	21	462.700
6	462.688	14	467.713	22	462.725
7	462.713	15	462.550		
8	467.563	16	462.575		



CHANNEL CROSS REFERENCE CHART

15 CHANNEL GMRS	22 CHANNEL FRS/GMRS	14 CHANNEL FRS
1	1	1
2	2	2
3	3	3
4	4	4
5	5	5
6	6	6
7	7	7
CHANNEL NOT AVAILABLE	8	8
	9	9
	10	10
	11	11
	12	12
	13	13
	14	14
11	15	CHANNEL NOT AVAILABLE
8	16	
12	17	
9	18	
13	19	
10	20	
14	21	
15	22	





LICENSING INFORMATION

FRS (Family Radio Service) channels operation-none required.
 GMRS (General Mobile Radio Service) channels operation-requires operator licensing, call sign etc. For further information, contact the FCC at www.fcc.gov

GMRS Licensing Eligibility: An individual 18 years of age or older, who is not a representative of a foreign government, is eligible to apply for a GMRS system license. Individual family members are all ages are subsequently eligible to operate GMRS stations and units within the licensed system.

This device complies with Part 15 of the FCC rules. Operation is subject to the following two conditions: (1) this device may not cause harmful interference, and (2) this device must accept any interference received, including interference that may cause undesired operation.

SERVICE

(U.S.) Should your unit require service, please contact the Nady Service Department via phone at (510) 652-2411 or E-mail at service@nady.com. Any installation or operating questions should be directed to our service department. Do not return the unit to the store before calling us. We can probably help you with one short phone call or E-mail.

(International) For service or questions, please contact the Nady MRC-11X motorcycle accessories distributor in your country through the dealer from whom you purchased this product.



NAVIGATING MENU

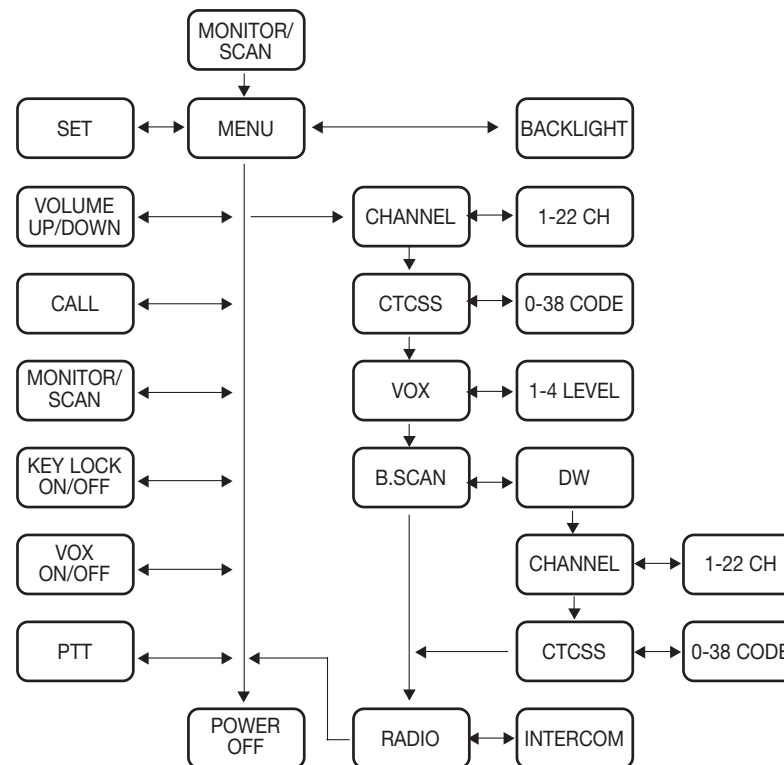

CALL TONE SETTING

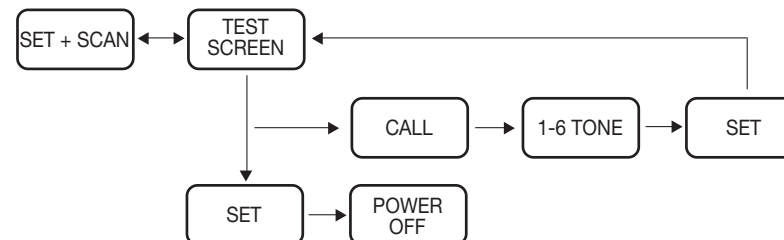



NADY SYSTEMS, INC.
nady.com

